

# Dream machine in three steps





## Dear restaurateurs, hoteliers and caterers

The catering trade has changed and advanced all over the world. Restaurants, coffee shops, snack bars and fine dining restaurants, are all offering food to suit every taste – and doing so 24 hours a day. As different as the offerings are, just as different are the demands placed on commercial dishwashers to deal with the difference types of dirt and items being washed.

The basic conditions for professional dishwashing are undergoing profound changes. Scarce resources on world markets have created a new awareness of consumption and operating costs. They have become essential criteria in investment decisions.



Winterhalter is the specialist for professional dishwashing systems. We offer dishwashing solutions which are perfectly tailored to your needs – from the machine to detergent products, water treatment and accessories, all the way to the right racks.

In-depth reviews of customers' wishes in personal talks and a worldwide survey were important sources of inspiration for developing „the dream machine“. Our new under counter dishwasher series, is the result of a unique machine concept. It takes only three steps to reach a solution of your very own.

Our new under counter dishwashers are not only economical, but also easy to operate, making your daily workload a great deal easier. Thanks to intelligent technology, these dream machines can control the dishwashing process, making things much easier for you. At the same time, hygienic and clean dishes are guaranteed.

As a technology and market leader of many years' standing in the area of under counter dishwashers, Winterhalter's dream machine is once again setting new standards. It stands for tailored dishwashing solutions, promising a new level of quality you will appreciate after every washing cycle for years to come.

We would like to extend a cordial invitation to you to discover your dream machine!

Jürgen Winterhalter

Ralph Winterhalter



■ Your dream machine [Page 4](#)



■ Glasswashers [Page 6](#)



■ Dishwashers [Page 8](#)



■ Bistro dishwashers [Page 10](#)



■ Cutlery washers [Page 12](#)



■ UC Energy [Page 13](#)

■ The concept of the dream machine	
→ Dishwashing results & Hygiene	<a href="#">Page 14</a>
→ Operating the machine	<a href="#">Page 16</a>
→ Standard & individuality	<a href="#">Page 18</a>
→ Economic efficiency	<a href="#">Page 20</a>
→ Quality & environment	<a href="#">Page 22</a>
→ Technical data	<a href="#">Page 24</a>



## Your dream machine

# The way to your dream machine



One possible design option.

Individuality is the trump card. The new under counter dishwashers gives you a choice between type of application, machine size, equipment and design.

The **UC Series** of under counter dishwashers from Winterhalter adapt to **your wishes**. Every pub or restaurant has its own character and its very own requirements, from the wash items to the available space. The **revolutionary concept of the UC Series** makes Winterhalter the first supplier to take this into account. The dream machine can be customised by using the **following three steps**:

**Step 1:** **Four types for different applications** with up to three standard programmes:

- glasswasher
- dishwasher
- bistro dishwasher
- cutlery washer

**Step 2:** **Four sizes:** S = small, M = medium, L = large, XL = extra large

**Step 3:** **Individual equipment features:** Energy, integrated softener, integrated partial demineralisation unit DeMatik Pi-240, rack packages, **designs** for the machine front etc.

After the dream machine has been configured, a whole new dimension of dishwashing becomes available to you.



### Easy to operate

The new way of operating a dishwasher: **the touch screen**. It is child's play to use. Along with the time-tested Winterhalter single-button control, there are three washing programmes available accompanied by **self-explanatory symbols**. This guarantees intuitive, error-free operation.



### Dishwashing to perfection

A large number of technical innovations have enabled Winterhalter to achieve **dishwashing results of a quality never seen before**. This has been confirmed in a series of tests conducted by independent testing institutes.



### Economical to operate

The dream machine always aims at being as **economical as possible** to run. In addition, the Energy design offers the option of saving additional energy based on a **circulating air heat recovery** system.



Four machine types, four sizes – this is what the new generation of under counter machines from Winterhalter has to offer: glasswashers, dishwashers, bistro dishwashers and cutlery washers that all come in sizes S, M, L and XL.



The professional Winterhalter glasswashing solutions can cope with every kind of glass thanks to a system that encompasses the machine, detergent products, water treatment, accessories and the right racks equipped with rack tops and dividing stays.

## Glass washing specialist for brilliant results

**Gleaming clean glasses are the calling card for your establishment.** That is why using a professional glasswasher is an absolute necessity. The UC Series of Winterhalter machines ensures **glass washing** at the **highest level of hygiene** while at the same time being as **economic as possible**. Four machine sizes to choose from – S, M, L and XL.

**A glass is not always simply a glass:** a thin-sided wineglass in a bar or restaurant must be treated differently to a pint glass in a pub. That is why the new glasswashers **automatically adjust the components for the wash process, in particular, water pressure, time, detergent and temperature, by way of three preset programmes**. This guarantees hygienically clean glasswashing results. The programme is selected **intuitively with appropriate symbols on the touch screen**, greatly reducing operator errors.



**Perfectly clean – more than just meeting the minimum standard.** From lipstick to dried milk froth, up to fruit flesh: the demands are many and varied.

**The new elliptical upper and lower wash fields glasswashing** ensures full-coverage dishwashing power that masters even stubborn dirt. Floating particles, such as fruit flesh and coffee grounds, are efficiently eliminated by the **fourfold wash water filtration system with turbidity sensor**, so that the wash water stays permanently clean.

**The right solution for every glass – thanks to VarioPower** Long-stemmed wine glasses, small apéritif glasses and champagne flutes fall over easily because of their shape and the water pressure in the washer.

**VarioPower controls the water pressure** in every washing programme – the stability of fragile glasses is also ensured. The other wash components are adjusted to achieve ideal wash results even at low pressure. This way, **fine wine glasses** get just as clean **at low water pressures** as **robust beer mugs** **at high water pressures**.

**Less glass abrasion, long-lasting decorations** Milky glasses, glass abrasion, faded decoration – all familiar problems. These are problems caused by high washing temperatures and incorrect detergent dosing.

Winterhalter glasswashers are gentle as standard. **Adequate washing and rinsing temperatures, different water pressures depending on the programme, and precise detergent dosing** ensure that your glasses will last a long time. The **Winterhalter system** supports the ideal treatment for your glasses with the right water treatment and detergent that is gentle on decorations.

**Special solutions – in all four sizes** When glasses do not cool down after being washed, the quality of the drink suffers. This is because cold drinks are unpalatable in warm glasses and the beer head quickly disappears.

The **Cool version rinses the glasses with cold water**. This saves waiting times and ensures a stable beer head.



## A fan of cleanliness, offering a strong helping hand

The new Winterhalter UC Series adapts flexibly to size, shape and how dirty the wash items are, yet constantly delivers perfect dishwashing results.

**The kitchen is a world of diversity:** African, Asian and European specialities are a common element of today's menus, along with local cuisine. Hence the types of ware and kinds of dirt are as varied as the dishes being served.

The **under counter dishwashers** meets these different requirements whilst keeping the same high standard of quality. Whether the wash items are slightly or very dirty, whether starch, fat or protein – the results are **always hygienically clean**. The new Winterhalter dishwashers even take account of **different shapes and sizes**, from fragile Japanese soup bowls to large, robust pizza plates.



For this purpose, **defined programmes automatically adjust the components responsible for the dishwashing process, especially water pressure, time, detergent and temperatures to the respective wash items and how dirty they are.** The programme is selected intuitively by choosing the matching wash item symbol, which simultaneously indicates **how dirty the wash items are.** This dramatically reduces operator error.

You can choose the size that best fits your wash items combined with the space available, from the four **machine sizes, S, M, L and XL.**



**Clean dishes – a gleaming impression**

In many establishments, it is not possible to pre-clean by hand because of space and time. The demands on the dishwasher are similarly high.

**The unique, elliptic wash fields** with specially developed **nozzles** achieve maximum **coverage** and cleaning power from above and below. The innovative **fourfold wash water filtration system with turbidity sensor** ensures clean wash water.



**Stability for light items**

If the washing pressure is too high, small or light-weight pieces fall over and can therefore not be thoroughly cleaned.

Thanks to **VarioPower**, Winterhalter can individually regulate the washing pressure. By selecting the appropriate programme, **light dishes in particular, reliably stay in position** and are washed clean. The other wash factors also adapt automatically.



**Put an end to stubborn dirt**

Even small kitchens can have especially dirty wash items that often have to be washed several times or even by hand.

A specially configured programme enables **dishwashing at especially high water pressure** and guarantees that even **very dirty wash items are washed hygienically clean** whilst at the same time being economically efficient.



**Maximum capacity for trays**

Some pubs, hotels and restaurants not only wash dishes but also larger items such as trays.

Washing these by hand costs a great deal of time, water and energy. The **UC-XL has an extra deep interior** which efficiently and hygienically washes trays.



## An expert in varied use

Snack bars, coffee shops and bistros offer a wide range of warm and cold dishes, as well as beverages, in the smallest of spaces. **Winterhalter bistro dishwashers** are the machines of choice for these types of establishment. That is because these all-round machines can get cutlery, glasses and dishes hygienically clean in one cycle. Depending on the space available or the requirements of your wash items, you can choose from **four sizes S, M, L and XL**.

Along with a **programme for combined dishwashing**, two other programmes are available which enable **glasses or other specific wash items to be washed seperately**. Depending on how the machine is loaded and the chosen programme, this **automatically adjusts the components responsible for the dishwashing process – in particular, water pressure, time, detergent and temperatures**. Easy and uncomplicated to operate, the **three defined standard programmes** can be selected using symbols for the respective kind of wash items.

The bistro variants of the UC Series make for a perfect team along with the right bistro combination racks and detergent products from Winterhalter.





#### Ready for varied use

In a bistro, a wide variety of different wash items, from glasses to cutlery to plates, have to be washed hygienically clean in a very small space.

Washing multiple items together introduces various types of dirt. Thanks to the **fourfold wash water filtration system with turbidity sensor**, floating particles, such as fruit flesh and coffee grounds, are filtered out. Thus the wash water stays permanently clean.



#### Gleaming glasses

Glasses are expected to be just as hygienic as dishes – yet glasses are more sensitive. That is why a rinse water temperature of 65 °C is recommended.

If **the same sort of glasses are to be washed together**, the appropriate predefined programme is simply selected using the **glass symbol on the touch screen**. This guarantees optimum wash results and at the same time prevents glass corrosion.



#### Clean dishes

As a rule, plates are the dirtiest wash items and also have the most stubborn kinds of dirt: protein, fat and starch have to be eliminated without leaving a trace.

The **special dishwashing programme** in the bistro dishwashers washes with **more water pressure and a higher rinse water temperature**. This combination ensures perfect cleaning and drying, even if the wash items are very dirty.

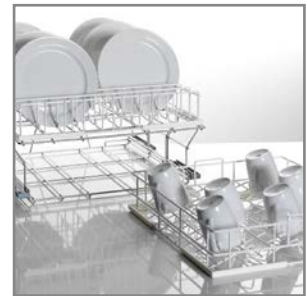

#### Double-rack system

The UC-L with its double-rack system is ideal for bed & breakfasts and restaurants using lots of smaller plates, cups and dishes. By using the twin racks, washing capacity is doubled while operating costs are cut in half. The double-rack system consists of a stainless steel rack holder for two racks – a cup rack and a plate rack.



Winterhalter has added cutlery washers to its range of under counter dishwashers particularly to meet the high demands of prestige restaurants.

→ Cutlery washers 

## Specialist for perfect results without polishing

The cutlery washers from Winterhalter guarantee hygienically clean washing and cutlery without any visible traces of dirt while saving considerably on time and expense. If fully demineralised water is used, **there is no need to waste time in unhygienic polishing**, because spotless cutlery is ready to use at the flick of a switch. These cutlery washers come in **four different sizes** in order to fit in any sort of space.

In the Winterhalter system, all components contribute to perfect dish-washing results. That is why Winterhalter recommends pre-soaking cutlery in a basin. Special racks ensure that the cutlery is washed standing upright. This guarantees perfect cleaning and drying results.

## Energy saver for excellent room atmosphere

Winterhalter first presented its successful Energy concept in the under counter class of dishwashers. When the door of a conventional dishwasher is opened at the end of a programme, it allows warm, humid water vapour to escape. This is valuable energy that just dissolves into thin air. **The Energy designs of the UC Series transform this energy into a valuable resource with the aid of a circulating air heat exchanger.**

The **reduction** of energy consumption needed to heat up the rinse water amounts to **48 % or 0.1 kWh per cycle**. Assuming 80 cycles per day, this is a saving of 2920 kWh or **energy expenses of up to € 613,-** per year. Another advantage is that the **room atmosphere improves**, since opening the dishwasher door allows almost no hot, damp water vapour to escape.

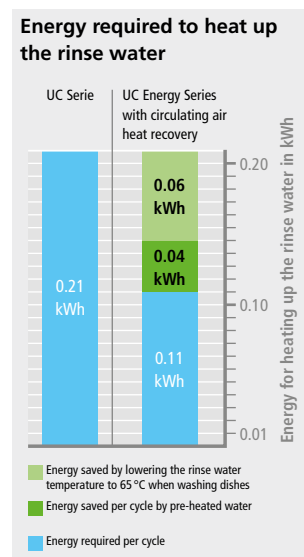

→ You will find further details in the „Economic efficiency“ chapter on page 20.



Circulating air heat recovery, European patent



## The highest performance with the best results

Achieving perfect, hygienically clean results when washing dishes is the most important job for a dishwasher, especially when the wash items are soiled by especially stubborn dirt. Winterhalter has a large number of advanced developments and technical innovations, such as the new **elliptic washing field with specially arranged nozzles**, to ensure that its new **under counter dishwashers** absolutely deliver the highest performance.

VarioPower has a double elliptic washing field and variable water pressure control to ensure the best possible dish-washing results. At the same time, the machines are gentle on the ware.

Thanks to **VarioPower**, Winterhalter can individually regulate the wash pressure. By selecting the appropriate programme, fine, delicate dishes are washed gently using a lower water pressure; heavy, robust dishes on the other hand are washed with more power using greater water pressure. The other wash factors adapt automatically – always guaranteeing a perfect result.



### Complete coverage

Only **maximum coverage** can guarantee perfect, hygienically clean dishwashing results. For this reason, Winterhalter's engineers put a lot of time and expertise into developing the new **elliptic washing fields with integrated washing and rinsing nozzles**. A striking characteristic of these nozzles is that each has a different shape, size and angle.

The two revolutionary washing fields ensure **uniform coverage and dishwashing power** from above and below.



### Efficient fourfold wash water filtration system,

**Stage 1: The strainer filters** coarse dirt out of the wash water and draws it to the coarse filter of the removable cylinder.

**Stage 2:** Smaller particles of dirt are held by the cylinder's fine filter.

**Stage 3:** Tiny particles, such as coffee grounds, are filtered out through the time-tested **Mediamat**.

**Stage 4:** A pump inlet filter protects the circulating pump from damage. **A clouding sensor monitors the wash water quality and starts gradual regeneration if necessary.**



### High-performance hygiene tank heater

The hygiene tank heater is located **right in the dishwater**, where it ensures a **constant, optimum tank temperature**. Its smooth, closed surface is **less susceptible to lime and dirt deposits**.



# A responsible, considerate communicator

**Operating a dishwasher must be so simple that it requires very little effort.** Using the UC Series is child's play and language-independent thanks to its **touch screen**. The correct wash programme can be selected, depending on the wash items and soiling levels, by touching the corresponding symbol on the screen. Visual and acoustic signals keep the staff informed of the progress of the dishwashing process and the status of the machine. In addition, the machine can identify and show errors, and in some cases even remedy them itself. In this way, the UC Series assumes **active responsibility**. The touch screen is not only a navigation instrument, but also provides a great deal of important information for the chef and service technicians.



### Touch screen

The touch screen is a platform for operation, communication and control.

#### Operating menu

- Programme selection
- Operating instructions
- Service addresses
- Temperatures
- etc.

#### Chef menu (PIN-protected)

- Display of operating/hygiene data
- Settings for the auto-boot function
- etc.

#### Service menu (PIN-protected)

- Change all settings
- Adapt to individual customer needs
- etc.

#### Start key with progress bar

The time-tested

Winterhalter start key is at the same time a progress bar, for it changes colour from blue to green in the course of the dishwashing cycle. In this way you can see at a glance how far along the programme is.

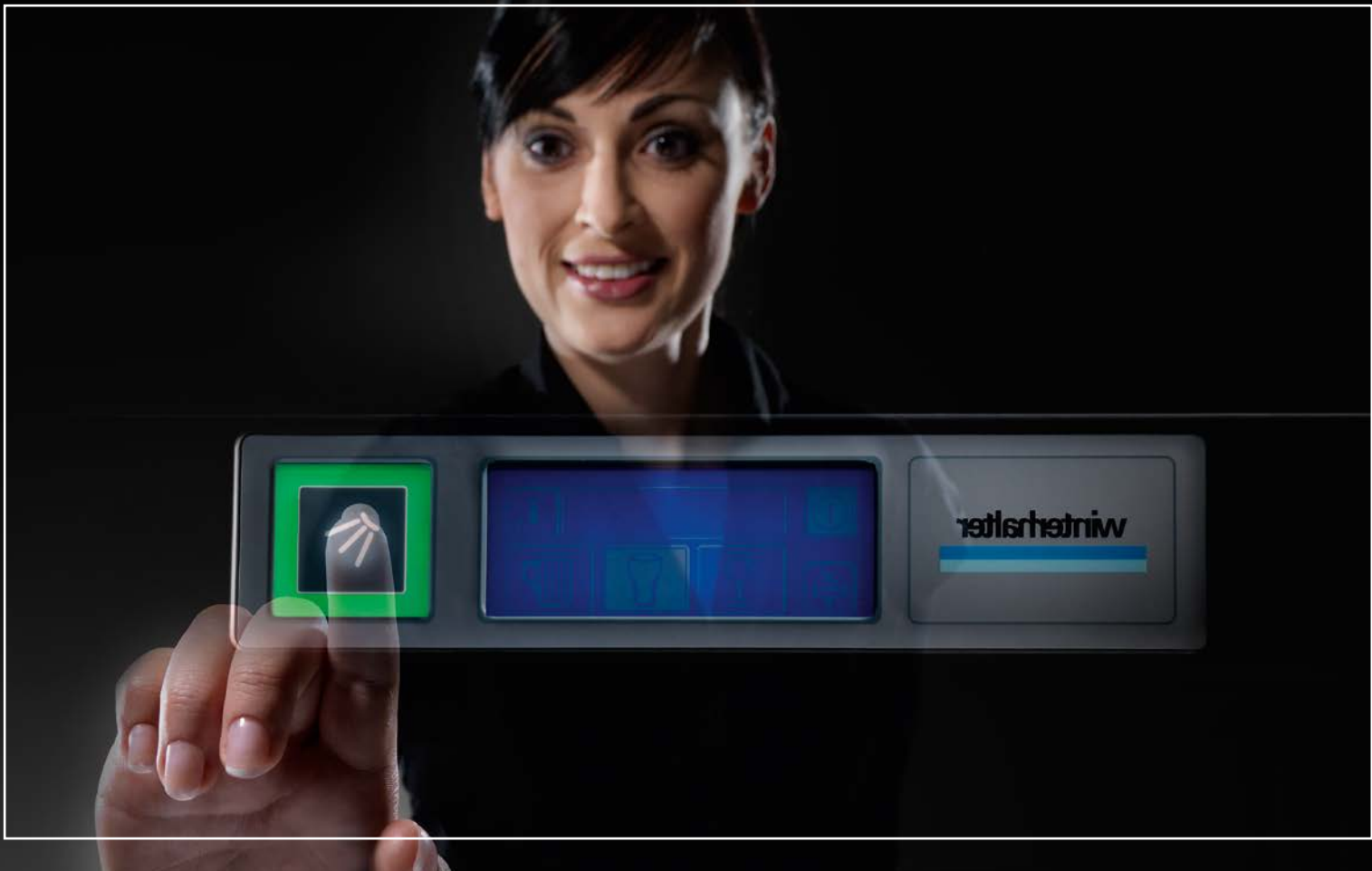

### Operating menu

**Animated operating instructions and dish-washing tips** on the right way to use the dishwasher are always at hand. This enables new staff to familiarise themselves quickly with the dishwasher. No time-consuming instructions are required.

**Maintenance interval display**

The dishwasher automatically reminds you that maintenance is planned. This enhances service life and long-term maintenance.

**Error display**

Visual and acoustic signals draw operators attention to quickly identify problems, such as wash items blocking wash fields or lack of detergent or rinse aid. This enables staff to take immediate action and optimises wash results and the life of the machine.

Data relating to chemical suppliers and service history can be quickly retrieved with a simple touch of the screen.



### Chef menu

**The operations log** is an information and control instrument for identifying operator habits and, if appropriate, change them. Consumption, capacity and information on water treatment and service intervals can be retrieved.

**The integrated hygiene log** is for documenting events relevant to hygiene, such as programme selection, dishwashing behaviour and malfunctions.

**Special programmes: descaling and basic cleaning**

In areas with hard water, there is a possibility that the dishwasher could be susceptible to limescale build-up. The descaling programme can help to extend the machine's service life. The basic cleaning programme is able to remove starch deposits from the wash items.





















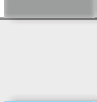

## Dishwashing pro that meets every requirement

Winterhalter is the first supplier to develop a dishwasher, the UC Series, in which not only the dishwasher itself, but also the **programmes** can be tailored to the **individual wishes** of restaurateurs, hoteliers and caterers. On this dream machine, some factors that effect the dishwashing result can be adjusted: **water pressure, washing and rinsing temperature, rinse water amount, detergent and rinse aid amount and dishwashing time.**

Every model has up to **three standard programmes** in which the factors listed above are predefined to match the respective wash items and conditions.

It is possible for settings to be adjusted on your premises by the service technician to meet the specific needs of your business. A library of symbols can be aligned with your specific wash items and settings made accordingly. Winterhalter is setting standards of operating comfort and dishwashing results.

	 Wine glasses	 Juice glasses	 Beer mugs
Rinse water amount			
Rinse aid amount			
Detergent amount			
Rinse water temperature			
Water pressure			
Dishwashing time			

The wash items and level of soiling defines the programmes: The UC Series stores programmes with ideal settings for specific wash processes. (Here is an example for a glasswasher).

**Three standard programmes for washing glasses.** Fragile wine glasses are washed at low water pressure, whilst robust beer glasses are washed at higher water pressure.



**Three standard programmes for washing dishes.** The first programme washes small, easily soiled pieces of crockery. The medium programme washes large, normally dirty plates. The third programme is for larger, very dirty items including pots and pans.



**Three standard programmes for washing bistro items.** Along with the bistro programme for washing glasses and dishes at the same time, there is a programme on offer for washing sturdy glasses alone, as well as a programme for washing very dirty items by themselves.



#### Innovative special programmes

- Short programmes
- Intensive programmes – for dried on food residues
- Silence programmes – for quiet operation
- ECO programmes – for more quiet and economical operation
- Individual, user-configurable special programme
- Descaling programme
- Basic cleaning programme for ware
- Controlled self-cleaning program



## Extremely prudent cleaning expert

No kitchen can afford to ignore resource conservation, particularly energy. With the UC Series, this demand is met in a wide variety of aspects.

**The ECO programmes, the low-temperature warewashing system effect with reduced tank and boiler temperatures and the Energy design with patented circulating air heat recovery guarantee the lowest possible operating costs and ensure low rates of energy consumption.**

Additional savings on **working hours, water, energy, detergent and rinse aid** are enabled by the fourfold wash water filtration system with sediment sensor. It **guarantees constantly clean dishwater without having to refill the tank.**

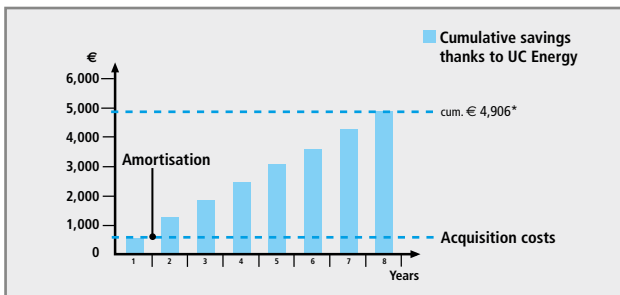

\* Basis of calculation, UC Energy (dishes):  
 $0.10 \text{ kWh/cycle} \times 0.21 \text{ €/kWh} \times 80 \text{ cycles/day} \times 365 \text{ operating days/year} \times 8 \text{ years} = \text{€ } 4,906$

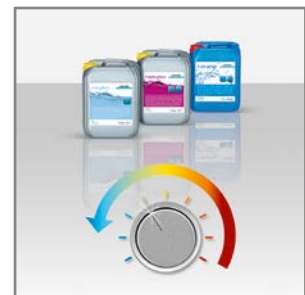

### Energy recovery with the Energy versions

Winterhalter is the first manufacturer to succeed in developing a **compact circulating air heat exchanger** for under counter dishwashers and thus to **recover heat efficiently in the smallest of spaces**. The hot, humid water vapour is extracted directly from the machine's interior. Its **energy is used to heat up the cold inlet water**.

This reduces energy consumption by **0.1 kWh per cycle**. Assuming 80 cycles per day, this saves **up to 2920 kWh** or energy expenses of **€ 613,- per year**. The UC energy is profitable in more than one respect: It improves the room atmosphere, saves energy and is good for the environment.

### ECO programmes

The ECO programmes wash especially economically. Longer washing time **enables water, energy and detergent products to be saved** without having the dishwashing quality suffer. These economy programmes are always a good choice when more time is available for dishwashing.

### Low-temperature ware-washing, effect\* system

The effect system allows you to reduce your operating costs by approx. 10 %, due to reduced tank and boiler temperatures. The effect system can be used in both glasswashers and dishwashers and is fully operational right from the start – without any investments. The rinse aid and two special detergents of the effect system, are perfectly suitable for use with dirty dishes or glasses, guarantees cleanliness and a brilliant shine, whilst guaranteeing hygiene safety at the same time.

\* Not available in all markets.  
 Inlet water temperature max. 50°C for glasswashers/max. 60°C for dishwashers.



## Tough workhorse with longevity

By putting great effort into development, **Winterhalter achieves its high standard of quality through combining technology and design with the best possible materials.** The new elliptical wash fields are a good example of this where we have combined high-quality, fibreglass-reinforced plastic which can be precisely shaped unlike stainless steel.

New technologies are an important driving force and can be used successfully in other industries. They promote ongoing advanced developments in dishwashing technology. Hence Winterhalter has once again accomplished a **technological quantum leap** with its new UC Series. Of course, all aspects of **economic efficiency** and **environmental compatibility** are taken into account during development and production.



### **Best quality materials**

Extensive tests of materials in our own laboratories and our customers' practical experience testify to the above-average service life of the UC Series machines.

### **Economic efficiency and the environment**

In past years, Winterhalter has invested large sums in reducing the amount of energy, water, detergent and rinse aid required for commercial dishwashing. The result is the irt (intelligent resource technology) concept, whose aim is to develop machines in all product areas which deliver the best dishwashing results whilst using up fewer resources and are therefore environmentally sound. Thanks to reduced energy consumption, CO<sub>2</sub> emissions are also minimised.

### **Minimising waste and enhancing recycling capability**

Winterhalter pays attention to generating minimal amounts of waste and making its products as recyclable as possible. The primary component of the machines is stainless steel 1.4301. Plastic, electronic and stainless steel components are easy to separate so that the dishwasher can be recycled at the end of its service life.



One possible design option.

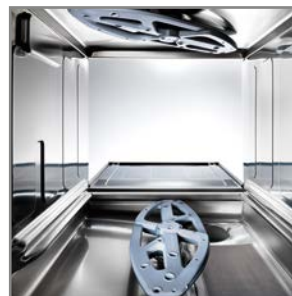

**Quality – made in Germany and Switzerland**

One employee is responsible for the complete machine and the final quality control in each case. This promotes responsibility and thus identification with the product. This also yields a **lower error rate and higher quality**.

**Machines are easy to care for**

The high quality standard placed on materials and workmanship, as well as ease of care and maintenance, are important conditions for a **long machine service life**. Two pushbuttons enable the washing fields to be taken out with one hand for cleaning without requiring any tools. All components of the wash water filtration system can easily be removed and rinsed off with water.

**Maintaining the machine's working life**

Various indications on the touch screen ensure continuous care and maintenance. The machine is capable of automatically indicating when a maintenance visit is required or a programme for decalcification may also clean the machine's interior if appropriate. The error management system quickly and efficiently identifies malfunctions and eliminates them.

**Easy to service/accessible**

The easily removable **front panel and individually removable side walls** make it easy to access the machine's components section. Parts needed for maintenance are also easy to access. Thanks to **automatic fault diagnosis and an actuator programme** (test programme for electrical components), the causes of faults can be quickly identified and eliminated. In fact, the new UC Series is remarkable in that its **service takes very little time**.



## Technical data

### UC-S

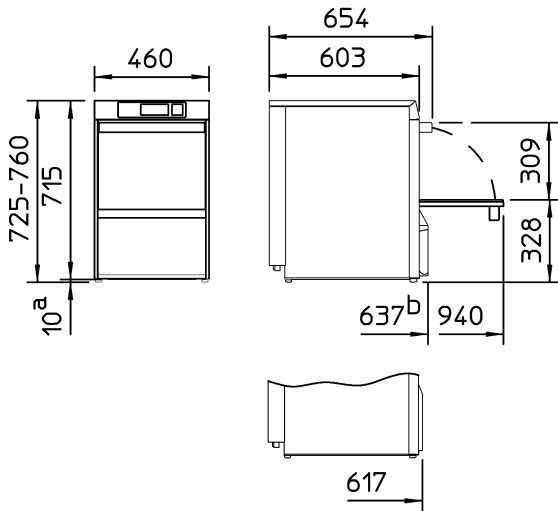

### UC-M

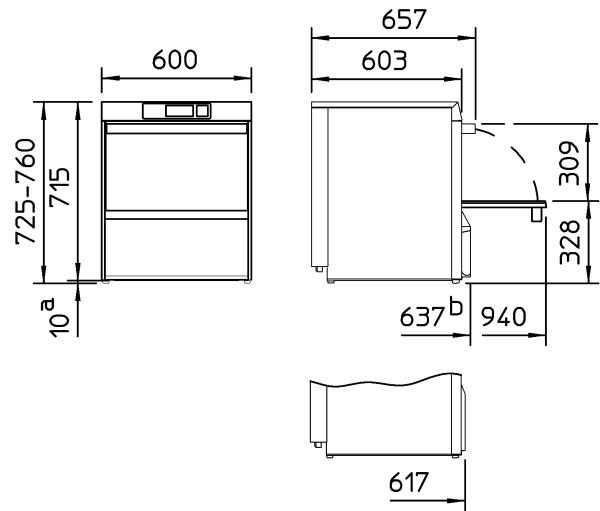

### UC-L

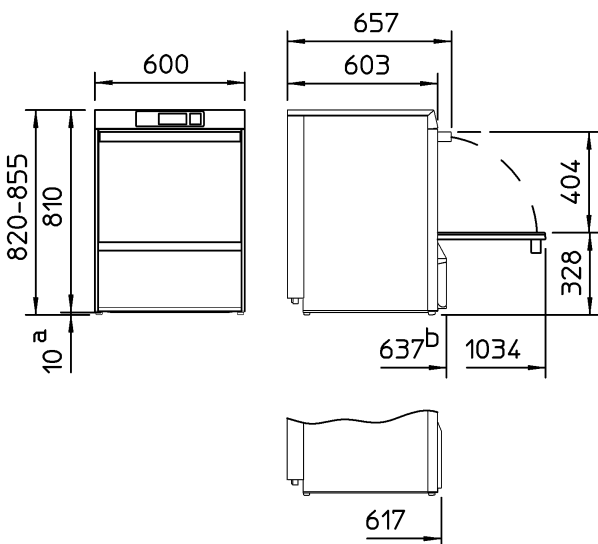

### UC-XL

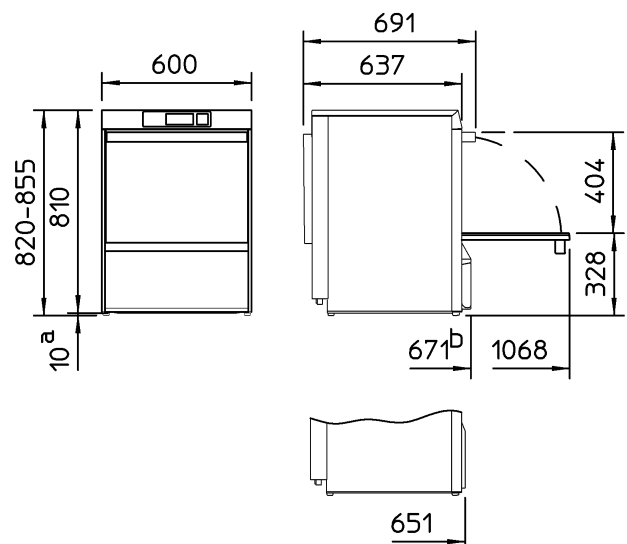

<sup>a</sup> By removing the feet, the machine height is reduced by 10 mm.

<sup>b</sup> Without included containers for detergent and rinse aid, the depth in all machines is reduced by 20 mm.

### UC-S Energy / UC-M Energy

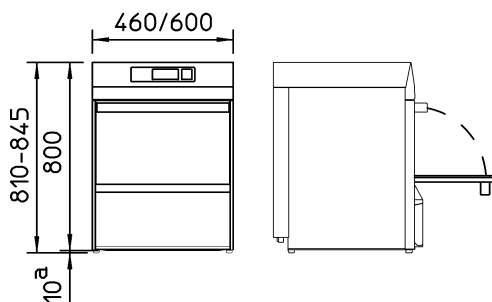

### UC-L Energy / UC-XL Energy

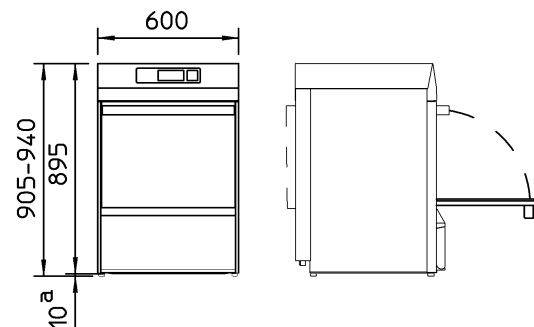

Adjustable feet enable the vertical dimensions to be raised at need by up to 35 mm.

## UC Series in general

Technical data	S	M	L	XL
<b>Number of programmes</b>	up to 3 (+ special programmes)			
<b>Theoretical capacity*<sup>1</sup></b> [racks/hr]	see machine model, page 26-27			
<b>Width</b> [mm]	460	600	600	600
<b>Depth</b>				
- incl. detergent container [mm]	637	637	637	671
- without detergent container [mm]	617	617	617	651
- with open door [mm]	940	940	1034	1068
<b>Height with feet*<sup>2</sup></b> [mm]	725-760	725-760	820-855	820-855
- with Energy design [mm]	810-845	810-845	905-940	905-940
<b>Clear input height</b> [mm]	309	309	404	404
<b>Rack dimensions</b> [mm]	400 x 400	500 x 500	500 x 500	500 x 500
				500 x 540
<b>Tank capacity</b> [l]	9.5	15.3	15.3	15.3
<b>Tank temperature*<sup>3</sup></b> [°C]	40-66	40-66	40-66	40-66
<b>Rinse water temperature*<sup>3</sup></b> [°C]	40-85	40-85	40-85	40-85
<b>Rinse water requirement per cycle*<sup>4</sup></b> [l]	2.4	2.4	2.4	2.4
<b>Tank heating</b> [kW]	differs by country and on-site electrical supply, see page 27			
<b>Boiler heating</b>				
- alternating current [kW]	differs by country and on-site electrical supply, see page 27			
- three-phase current [kW]	differs by country and on-site electrical supply, see page 27			
<b>Circulating pump (P1)</b> [kW]	0.6	0.6	0.6	0.6
<b>Total connected load</b>				
- alternating current [kW]	differs by country and on-site electrical supply, see page 27			
- three-phase current [kW]	differs by country and on-site electrical supply, see page 27			
<b>Maximum inlet water temperature</b> [°C]	60	60	60	60
<b>Required water flow pressure*<sup>5</sup></b> [bar/kPa]	1.0–6.0/100–600	1.0–6.0/100–600	1.0–6.0/100–600	1.0–6.0/100–600
<b>Splash guard</b>				
- with plastic back panel	IP X3	IP X3	IP X3	–
- with stainless steel back panel (Option)	IP X5	IP X5	IP X5	IP X5 (standard)
<b>Weight net / gross</b> [kg]	59/68	64/74	69/79	69/79
- with Energy design net / gross [kg]	64/73	70/80	75/85	75/85

\*<sup>1</sup> Customer's circumstances (inlet water temperature / electrical connection), may reduce the values stated here.

\*<sup>2</sup> Adjustable feet enable the vertical dimensions to be raised at need by up to 35 mm.

\*<sup>3</sup> Deviations, see machine type, page 26–27.

\*<sup>4</sup> Under ideal conditions. The rinse water consumption depends on circumstances on the customer's premises.

Deviations, see machine type, page 26–27.

\*<sup>5</sup> For UC Energy machines: 1.5–6.0 bar / 150–600 kPa.

For UC machines with DeMatik Pi-240: 2.0–6.0 bar / 200–600 kPa

### Note:

Take the following changes in the dimensions into account when installing in an alcove.

Height: + 5 mm

Width: + 10 mm

Depth: + 5 mm

See the installation diagram for more information.



## Technical data

### Glasswashers

Technical data	Standard	Cool	effect*7	Energy*5
Theoretical capacity, washing programmes 1/2/3*1 [racks/hr.]	22/32/48	22/32/48	20/20/20	22/32/48
Short programme [racks/hr.]	77	77	36	77
Rinse water requirement per cycle*2 [l]	2.4	3.4	2.4	2.4
Rinse water temperature [°C]	65	*3 / *4	50 / *4	65
Tank temperature [°C]	62	55	45	62

### Dishwashers

Technical data	Standard	effect*7	Energy*5
Theoretical capacity, washing programmes 1/2/3*1 [racks/hr.]	40/28/24	20/20/20	40/28/24
Short programme [racks/hr.]	66	36	66
Rinse water requirement per cycle*2 [l]	2.4	2.4	2.4
Rinse water temperature [°C]	85	60 / *6	65
Tank temperature [°C]	62	55	62

### Bistro dishwashers

Technical data	Standard	Energy*5
Theoretical capacity, washing programmes 1/2/3*1 [racks/hr.]	40/32/28	40/32/28
Short programme [racks/hr.]	66	66
Rinse water requirement per cycle*2 [l]	2.4	2.4
Rinse water temperature [°C]	65-85	65
Tank temperature [°C]	62	62

### Cutlery washers

Technical data	Standard	Energy*5
Theoretical capacity, washing programme 1*1 [racks/hr.]	11	11
Short programme [racks/hr.]	21	21
Rinse water requirement per cycle*2 [l]	3.4	3.4
Rinse water temperature [°C]	86	65
Tank temperature [°C]	69	69

\*1 Customer's circumstances (inlet water temperature / electrical connection), may reduce the values stated here.

\*2 Under ideal conditions. Fine adjustment is done at commissioning.

\*3 Depends on inlet water temperature.

\*4 Can be switched to 65 °C.

\*5 Inlet water temperature < 20 °C.

\*6 Can be switched to 85 °C.

\*7 Not available in all markets.

Inlet water temperature max. 50 °C for glasswashers / max. 60 °C for dishwashers.

## Electrical values

Voltage	Fuse protection	Tank heating	Total connected load	Boiler heating	Circulating pump (P1)	Countries
380 V – 415 V / 3N~	16 A	2.0 kW	7.9 kW	5.3 kW	600 W	Worldwide
380 V – 415 V / 3N~	10 A	2.0 kW	6.0 kW	5.4 kW	600 W	
220 V – 240 V / 1N~	16 A	2.0 kW	3.2 kW	2.6 kW	600 W	
220 V – 240 V / 1N~	20 A	2.0 kW	4.2 kW	3.6 kW	600 W	
220 V – 240 V / 1N~	13 A	2.0 kW	2.6 kW	1.8 kW	600 W	
220 V – 240 V / 1N~	10 A	1.8 kW	1.8 kW	1.2 kW	600 W	
380 V – 415 V / 3N~	20 A	2.0 kW	9.7 kW	7.1 kW	600 W	Australia
380 V – 415 V / 3N~	15 A	2.0 kW	7.7 kW	7.1 kW	600 W	
220 V – 240 V / 1N~	20 A	2.0 kW	4.1 kW	3.5 kW	600 W	
220 V – 240 V / 1N~	15 A	2.0 kW	2.9 kW	2.3 kW	600 W	
200 V / 3~	25 A	1.4 kW	6.9 kW	4.9 kW	600 W	Japan
200 V / 2~	20 A	1.4 kW	3.3 kW	2.7 kW	600 W	
230 V / 3~	25 A	1.8 kW	7.3 kW	4.9 kW	600 W	Belgium/ Malaysia*
230 V / 2~	16 A	1.8 kW	3.0 kW	2.4 kW	600 W	

\* Special voltage.

## Electrical values, Cool design

Voltage	Fuse protection	Tank heating	Total connected load	Boiler heating	Circulating pump (P1)	Countries
380 V – 415 V / 3N~	16 A	5.4 kW	6.1 kW	5.4 kW	600 W	Europe
220 V – 240 V / 1N~	16 A	2.8 kW	3.4 kW	2.6 kW	600 W	
220 V – 240 V / 1N~	20 A	2.8 kW	4.2 kW	3.6 kW	600 W	



One possible design option.

**Winterhalter** Gastronom GmbH  
Commercial Dishwashing Systems

Winterhalterstrasse 2-12  
88074 Meckenbeuren  
Germany  
Telephone +49 (0) 75 42 4 02-0  
Telefax +49 (0) 75 42 4 02-51 87

[www.winterhalter.biz](http://www.winterhalter.biz)  
[info@winterhalter.biz](mailto:info@winterhalter.biz)